



Safety and Security @ DFKI



Dr. Andreas Nonnengart, Dr. Werner Stephan
German Research Center for Artificial Intelligence (DFKI GmbH)

Hybrid Systems



- Integrated description of continuous and discrete behaviour
 - discrete events; continuous flow
- Control of technical systems
 - that interact via sensors and actuators
- Modelled with Hybrid Automata
- DFKI Expertise: Smart Factories Production Lines
- Verification with HAVLE
 - DFKI's own implementation
 - Sophisticated Modularization

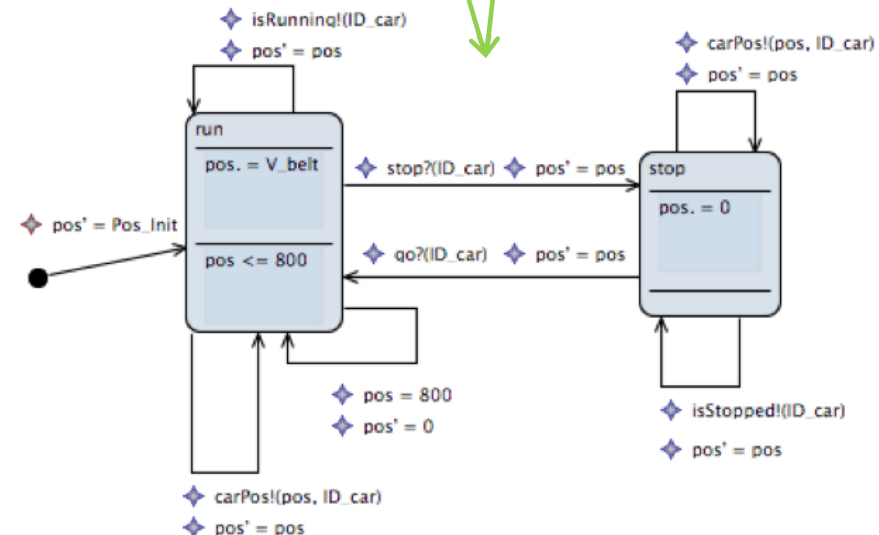
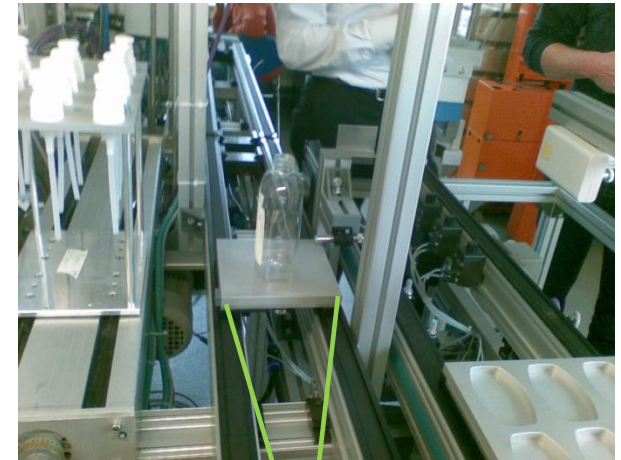

Features (what we can offer)



- Specification and Safety Analysis of Hybrid Systems (HAVLE)
 - object-oriented modelling
 - sophisticated synchronization & urgency mechanism
- Platform Integration concerning
 - determination of failure traces
 - planning of agent behaviours
 - refinement (of control models) to code level
 - service descriptions
 - animation (scripts)

Security by Design



Security as major success factor in many projects (applications) :

- confidentiality
- integrity
- privacy
- accountability

Security by Design

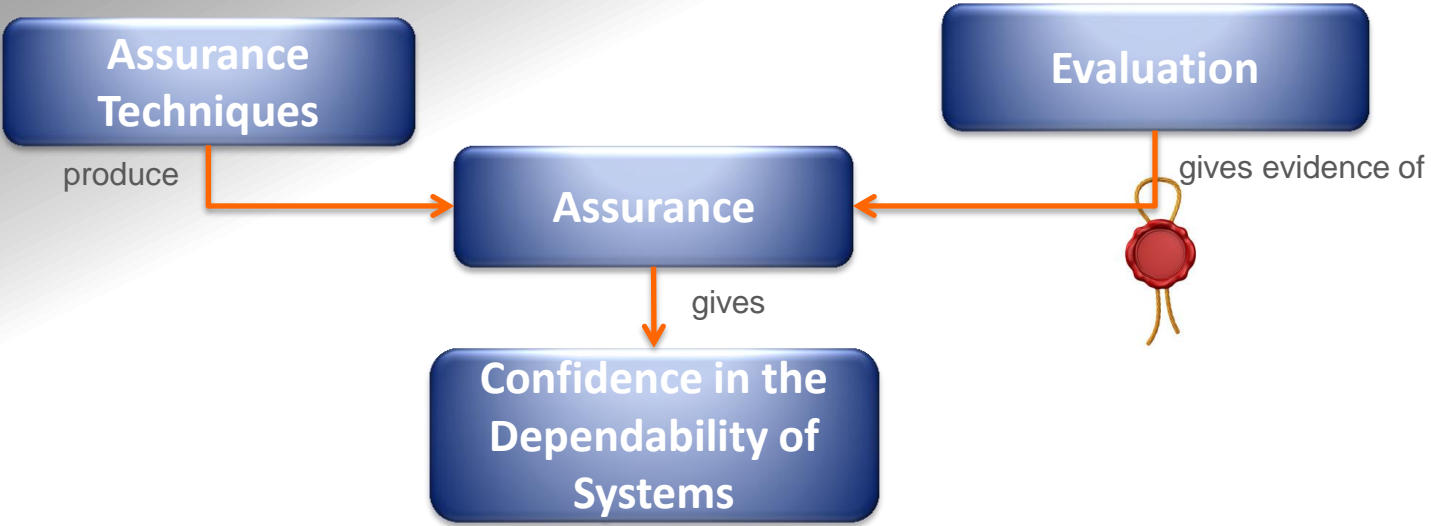

Security by Design



Assurance Techniques

produce

Assurance

gives

Confidence in the Dependability of Systems

Evaluation

gives evidence of



Provably Secure Systems



Certified Evaluation Body Consultancy



Common Criteria for Information Technology Security Evaluation



Security by Design

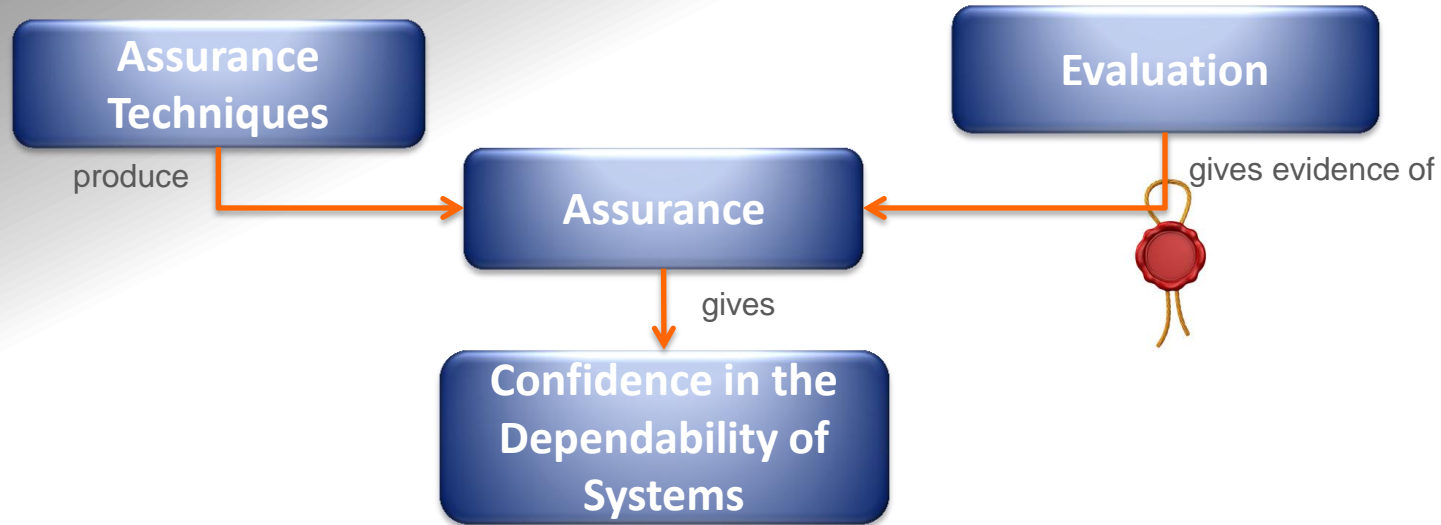

Services:

- comprehensive security analysis
- development and analysis of security mechanisms
- applying CC methodology: artifacts for certification
- (pre-) evaluation